

Drinking Fountain: Apollo 400

The Apollo 400 is a durable, vandal resistant outdoor disabled accessible fountain. It is just one of our fountains in the Apollo range designed for disabled access.

- Dimensions**
- Total Height: 845mm
 - Clearance Height: 680mm
 - 165 OD Steel Pipe
 - One piece heavy duty construction
- Finishes**
- Hot dipped galvanised prior to coating
 - Primed and powder coated
(Available in many different colours. [See colour selector.](#))
 - All fountains come with vandal resistant 316 stainless steel security screws
- Plumbing**
- In built water pressure regulator ½' inlet
 - 40mm Waste outlet pipe
- Options**
- Tap and Dog Bowl
 - Maintenance tap
 - Full parts and technical back up service available.
 - Service kits available for purchase
 - Button activated

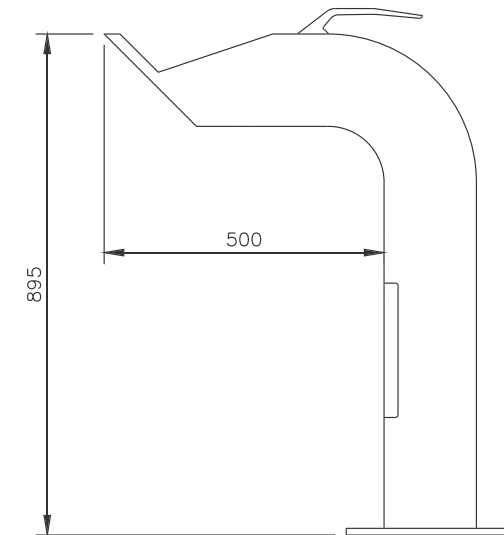
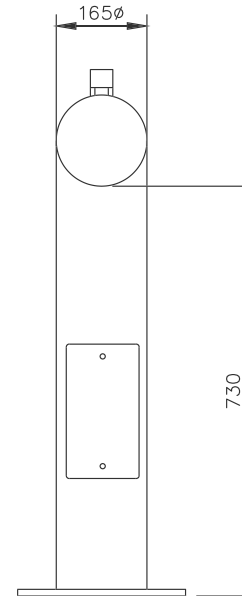

WaterMark

CMA-WM-080042
WMTS-105:2016



www.urbanff.com.au

07 3382 7372

office@urbanff.com.au

Urban
fountains + furniture